

DIY Shaker System Illustrative System Wiring

IMPORTANT – the arrangement shown is TYPICAL. PLEASE read the data sheet for full details of connections and operation.

For full details of the Pololu motor driver please read the Pololu driver documentation.

SHKR-1 Vibration Card

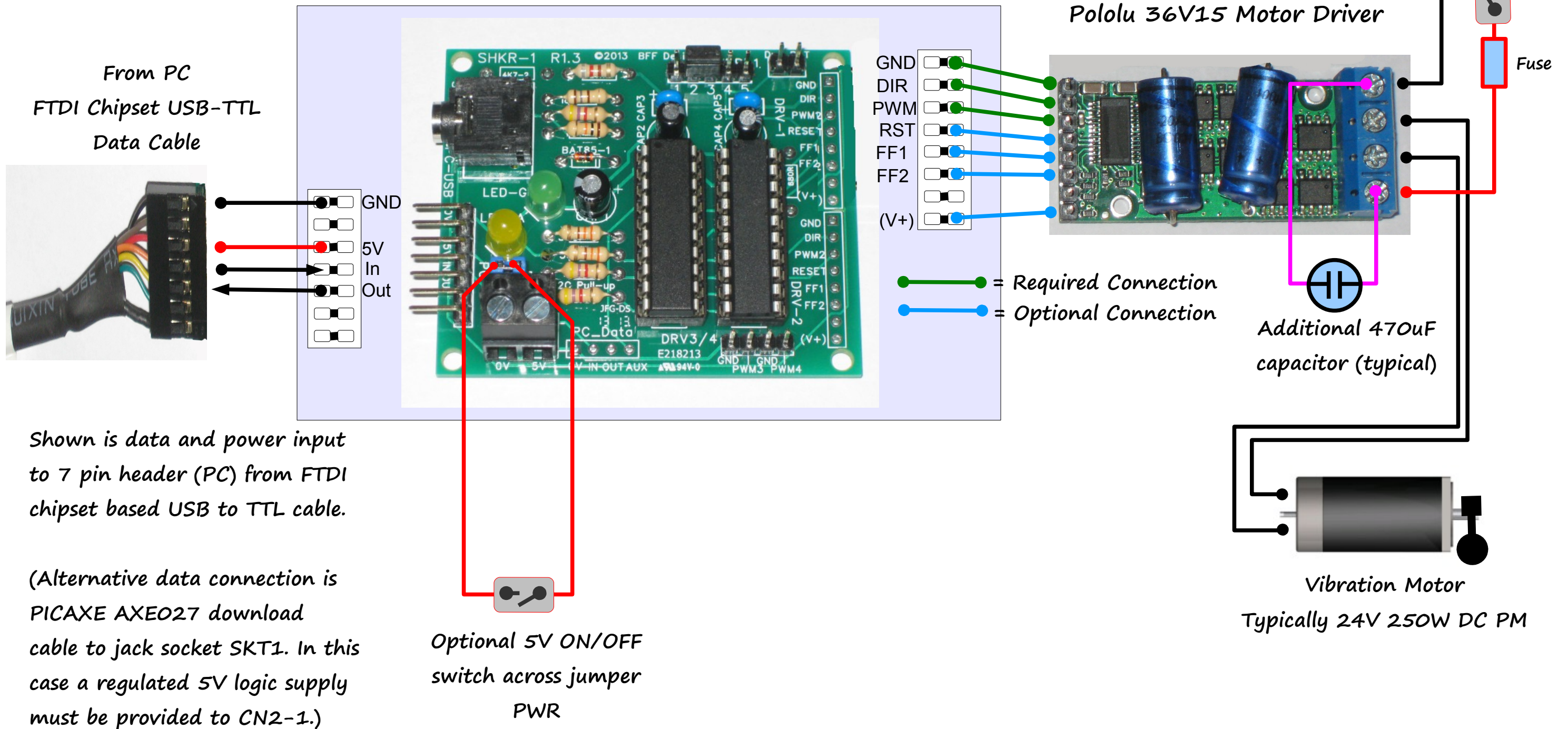

Shown is data and power input to 7 pin header (PC) from FTDI chipset based USB to TTL cable.

(Alternative data connection is PICAXE AXEO27 download cable to jack socket SKT1. In this case a regulated 5V logic supply must be provided to CN2-1.)